

Setting method

Select one of the **Tubtara**® blind rivet nuts out of our product range and a setting tool adequate for the application. Take a test workpiece and drill an appropriate hole

STEP 1

Screw the **Tubtara**® blind rivet nut (A) on the mandrel (B) of the setting tool. In the case of the open version, the mandrel should protrude about 1 mm. For closed rivet nuts, continue screwing until you feel resistance. Screw the anvil (C) against the head of the **Tubtara**® and block it with the locking nut (D).

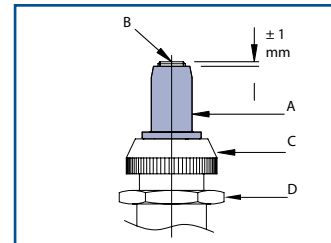

STEP 2

Insert the **Tubtara**® blind rivet nut, mounted on the setting tool, into the hole of the workpiece

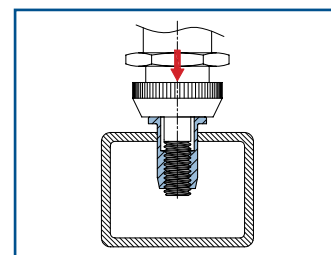

STEP 3

Set the **Tubtara**®. The Tubtara's deformation chamber now forms the counter head (bulb) on the underside of the workpiece

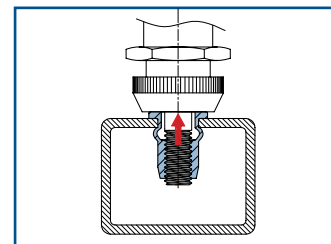

STEP 4

Unscrew the mandrel from the **Tubtara**®.

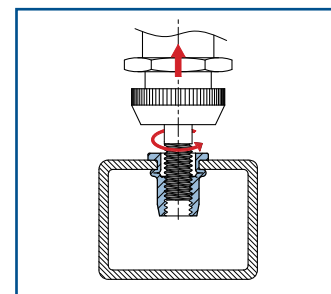

STEP 5

The **Tubtara**® blind rivet nut is now set. You can now easily insert your bolt or screw to assemble another component.

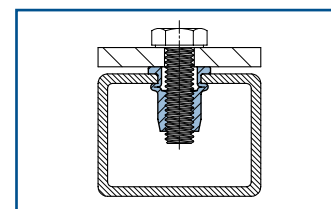

● Countersunk heads

Are you using a **Tubtara**® blind rivet nut with a countersunk head? Always countersink at 90° so that the head of the installed **Tubtara**® protrudes about 0.1 mm above your workpiece. This ensures direct contact with the assembled component.

Don't have the possibility to countersink?
Use a low profile head

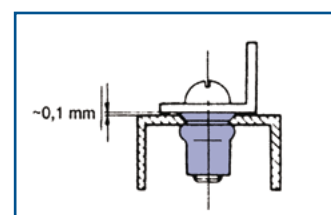

Materials

The **Tubtara**® is available from stock in steel, aluminium and stainless steel 304 & 316.

For critical bearing environments, we can also offer the following solutions to cope with most environmental conditions :

- superior cold formed stainless A5 or A6 quality on demand,
- several finishing options on stainless like Cadmium, ZnNi, Seal Inox®,
- passivated stainless steel.

Available from stock:

Material			W Nr
Aluminium	AlMg2,5	5052	3.3523
Steel	C8C	QST 34-3	1.0213
Stainless steel A2	304Cu		1.4567
Stainless steel A4	316Cu		1.4578

Available on request :

Material		W Nr
Stainless steel A5	316Ti	1.4571
Stainless steel A6	904L	1.4539

Material specifications are always subject to modifications.

● How to choose the right material ?

Choosing the right material and coating for your **Tubtara**® blind rivet nuts is very important for obtaining optimal functionality during the whole life cycle, especially when environmental conditions are unknown or critical. Influences can be chemical (elements dissolved in water), abrasive (sand), heat, friction, contact with other metals, corrosive environments, etc.

The ideal material choice is not always easy and all conditions should be taken into account. We therefore strongly advise to check the following tables and do some tests in the specific application environment in advance.



● Requirements & solutions

	Aluminium	Steel with appropriate coating	Stainless A2	Stainless A4	Stainless A5	Stainless A6
colour distinction		xxx				
visual identification		xxx				
weight-saving	xxx		x	x	x	x
durable	x	x → xxx	xx	xxx	xxx	xxx
easily recycable	xxx	xxx	xxx	xxx	xxx	xxx
electrical conductivity	xxx	xx	xx	xx	xx	xx
high/low temperature properties	x	xx	xx	xxx	xxx	xxx
non-magnetic	xxx		x	x	x	x
increased corrosion resistance	xx	o	xxx	xxx	xxx	xxx
resistant to atmospheric exposure	xx	o	xxx	xxx	xxx	xxx
resistant to chloride atmospheres		o		xxx	xxx	xxx
resistant to polluted environments		o		xxx	xxx	xxx
resistant to harsh environments		o			xxx	xxx
resistant to process fluids		o			xxx	xxx
top coating possible		xxx				
passivation possible			x	x	x	x

Legend	
o	possible influence
x	small influence
xx	larger influence
xxx	largest influence

● Galvanic couples

A suited material choice is not always easy and all conditions should be taken into account. The table below shows some connection guidelines for corrosion:

		Blind rivet nut material		
		zinc plated steel	aluminium	stainless steel 304 & 316
base metal wherein Tubtara is set	aluminium			
	zinc plated steel			
	brass, copper	T T®	T T®	
	stainless steel 4xx	T T®	T T®	
	stainless steel 304 & 316	T T®	T T®	

Legend	
	base metal and Tubtara ® ok
	base metal corrodes where in contact with Tubtara ®
T T®	base metal ok but Tubtara ® will corrode
	corrosion base metal heavily increased by Tubtara ®

We strongly advise to do some tests in the specific application environment. Samples are available on request.

Coatings

A suitable coating choice can offer additional characteristics to your **Tubtara**®.

- Coating on steel available from stock

Zinktop

High-quality Cr⁶⁺ & Ni free plating
 Conforms with ROHS 2, Reach, ELV directives
 96 h white rust - 480 h red rust
 10µ ±2µ

- Survey available coating offer



photo	coating description	standard / on request	salt spray test (h) ISO 9227		colour / aspect	corrosion protection	RoHS / Reach compliant	remarks
			white rust	red rust				
1	Zinc blue/white Cr ³⁺	REQ	24	72	blue/white	*	☑	Cr ⁶⁺ free
2	Zinc black Cr ³⁺	REQ	48	96	black	*	☑	Cr ⁶⁺ free
3	Zinc yellow Cr ³⁺	REQ	96	240	light yellow	**	☑	Cr ⁶⁺ free
4	Zinktop	ST	96	480	light grey	****	☑	Cr ⁶⁺ and Ni free
5	Zinktop Cobalt free	REQ	96	480	light grey	****	☑	Cr ⁶⁺ , Ni and Co free
6	Ultra 1000	REQ	240	1000	light grey	*****	☑	Cr ⁶⁺ and Ni free
7	ZnNi (Zinc Nickel)	REQ	quality according to customer's specs					
8	Vibraseal®	REQ	x	x	red, green			seals + anti-vibration
9	Gleitmo®	REQ	x	x	-			friction reduction
10	Seal Inox®	REQ	x	x	matt grey	*****		avoids galling
11	Passivation	REQ				*****		only on stainless steel

The Ultra 1000 is more than doubling the resistance to red rust in the salt spray test compared to the standard Zinktop. The offer of blue and black trivalent coatings, as well as the Cobalt free Zinktop, are developed to tackle imminent Reach regulations and can be delivered on demand.

* Zinc yellow Cr⁶⁺ plating is no longer standard and has been omitted from this catalogue.
 Due to REACH phase out, production of steel yellow hexavalent chromated parts has discontinued completely.
 For availability, only until depletion of stock, please contact our customer service.

● Stainless Steel

All stainless steel Tubtara's have been treated by a special process to obtain a natural passivation layer, improving the corrosion resistance compared to common stainless steel parts in the market.

Optional coatings on stainless steel are

- Gleitmo® / Seal Inox®
- full passivation.

● Why use a coating ?

Requirements & solutions :

	Zinktop on steel	Coloured plating on steel	Passivation on stainless steel	Gleitmo®	Vibraseal®	Seal Inox®	Molykote®
appropriate visual aspects		+					
colour distinction		+			o	o	
to avoid galling				+		+	+
reduction of friction				+		+	+
increase of friction				-		-	-
to avoid galvanic couple	o	o	+		+	+	
electrical conductivity	+				-	-	-
anti-vibration function					+		
increased corrosion resistance	+		+			+	
seal function					+	+	
UV illumination				+			

Legend	
-	negative influence
o	possible influence
+	positive influence

We strongly advise to do some tests in the specific application environment. Samples are available on request.



Technical Data

- General tolerances

	Head form	Dimensions in mm	Dimensions in inches
D (head diameter)	Flat head Countersunk head Low profile head	± 0,35 0 -0,5 -0,15 +0,3	±.014 0 -.020 -.006 +.012
K (head thickness)	Flat head Countersunk head Low profile head	±0,15 0 +0,3 -0,05 +0,3	±.006 0 +.012 -.002 +.012
L (length)	General Stainless M10 shank 13 mm	±0,35 ±0,5	±.014 ±.020
Metric thread= 6H			
Shank size	General (incl. KN) Splined shank (RS) M10 shank 12,4 mm	-0,02 -0,15 ±0,08 ±0,08	-.001 -.006 ±.003 ±.003

Example:

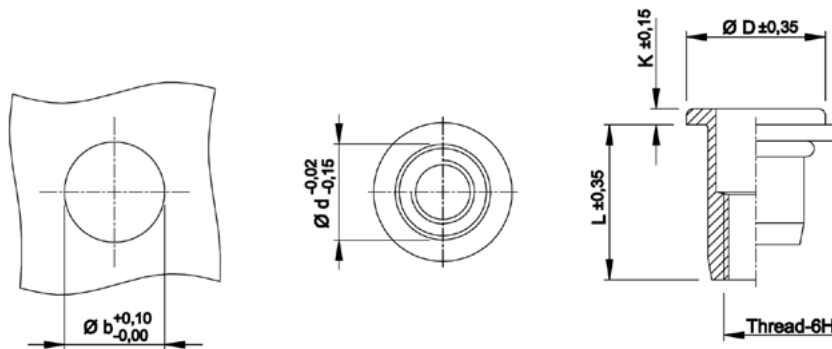

- Recommended tightening torque values (Nm)

Max. recommended torque to avoid damaging the threaded connection and ensure optimal screw-nut assembly:

	M3	M4	M5	M6	M8	M10	M12
Aluminium	2,0	2,2	4,5	9,5	17,0	30,0	
Steel	2,5	3,0	5,9	11,0	25,0	49,0	80,0
Stainless Steel	2,5	3,0	5,9	11,0	25,0	49,0	80,0

Recommendations for 8.8 bolts in steel and class A2-70 bolts in stainless steel.

● Mechanical properties

The tables below show some indicative standard values for Tubtara's with round or hexagonal shank and flat head in first grip for middle sheet thickness within range.

Mechanical reference values

product	material	pull-out	max. torque	torque-to-turn	shear test
		kN	Nm	Nm	kN
Round shank					
M3 UPO 20	Steel C8C	> 5,8	> 2,0	1,8	1,9
	Alu 5052	> 3,1	1,9	0,8	0,6
	SS 304Cu	-	-	-	-
M4 UPO 30	Steel C8C	> 10,8	> 7,5	2,7	2,6
M4 UPO 30	Alu 5052	> 4,5	4,9	1,4	1,1
M4 UPO 20	SS 304Cu	> 11,0	7,1	2,6	3,5
M5 UPO 30	Steel C8C	> 12,0	> 10,0	4,7	3,5
	Alu 5052	> 5,2	4,9	1,5	1,6
	SS 304Cu	> 14,5	> 16,0	3,0	4,8
M6 UPO 30	Steel C8C	> 21,0	> 19,0	7,0	5,0
	Alu 5052	> 10,5	16,0	3,2	2,4
	SS 304Cu	> 27,0	> 22,0	6,8	7,3
M8 UPO 30	Steel C8C	> 33,0	> 50,0	13,0	6,0
	Alu 5052	> 15,0	33,0	5,3	2,9
	SS 304Cu	> 40,0	> 70,0	9,0	9,0
M10 UPO 35	Steel C8C	> 40,0	> 70,0	15,0	8,0
	Alu 5052	> 20,0	39,5	7,0	3,7
	SS 304Cu	> 43,0	> 70,0	8,0	8,5
M10 SPO 35	Steel C8C	> 40,0	> 70,0	15,0	8,0
	Alu 5052	-	-	-	-
	SS 304Cu	> 43,0	> 70,0	13,0	8,4
M12 UPO 40	Steel C8C	> 63,0	> 120,0	32,0	11,5
	Alu 5052	-	-	-	-
	SS 304Cu	> 70,0	> 130,0	25,0	14,0
Hexagonal shank					
M4 HUPO 20	Steel C8C	> 8,8	> 7,5	> 5,5	2,6
	SS 304Cu	> 10,8	> 7,1	6,0	3,7
M5 HUPO 30	Steel C8C	> 12,0	12,0	> 6,5	3,6
	SS 304Cu	> 15,5	15,0	> 9,0	4,8
M6 HUPO 30	Steel C8C	23,0	> 24,5	> 21,0	5,1
	SS 304Cu	24,5	> 23,0	> 22,0	7,2

product	material	pull-out	max. torque	torque-to-turn	shear test
		kN	Nm	Nm	kN
M8 HUPO 30	Steel C8C	32,8	> 50,0	> 30,0	6,6
	SS 304Cu	39,0	> 64,0	32,0	9,4
M10 HSPO 35	Steel C8C	> 40,0	> 70,0	50,0	7,9
	SS 304Cu	> 43,0	> 70,0	> 50,0	10,2
M12 HUPO 40	Steel C8C	> 63,0	> 120,0	68,0	12,5
	SS 304Cu	> 70,0-	> 130,0	> 70,0	14,6

- Bolts class 8.8 were used
- > : value will be higher, but test could not be completed due to breakage of bolt or min. value is used as reference
- Steel plate (HRB 55) was used to set the **Tubtara®** (approximately middle of grip range)
- Shear test in most cases the **Tubtara** is pulled out of the sheet without shearing.

Geometrical reference values (open end parts)

product	material	setting force	stroke	size bulb forming	length under plate
		kN	mm	mm	mm
Round shank					
M3 UPO 20	Steel C8C	4,0	2,6	6,6 to 6,7	5,9 to 6,1
	Alu 5052	2,3	1,9	6,0 to 6,1	6,4 to 6,6
	SS 304Cu	-	-	-	-
M4 UPO 30	Steel C8C	4,5	2,8	7,8 to 7,9	6,7 to 6,8
M4 UPO 30	Alu 5052	2,2	2,7	7,7 to 7,8	6,8 to 7,0
M4 UPO 20	SS 304Cu	6,0	2,4	7,3 to 7,4	7,6 to 7,8
M5 UPO 30	Steel C8C	6,5	3,8	9,4 to 9,5	7,3 to 7,4
	Alu 5052	3,4	3,6	9,3 to 9,4	7,3 to 7,4
	SS 304Cu	8,0	3,5	8,9 to 9,2	7,3 to 7,5
M6 UPO 30	Steel C8C	9,5	4,0	11,6 to 11,8	9,3 to 9,6
	Alu 5052	4,9	3,3	11,2 to 11,3	10,0 to 10,2
	SS 304Cu	13,0	4,0	11,3 to 11,6	9,6 to 10,0
M8 UPO 30	Steel C8C	12,0	4,0	13,6 to 13,8	10,9 to 11,2
	Alu 5052	5,5	3,8	13,6 to 13,8	11,1 to 11,3
	SS 304Cu	15,4	4,2	13,6 to 13,7	11,3 to 11,6
M10 UPO 35	Steel C8C	14,5	4,4	15,7 to 15,8	14,4 to 14,5
	Alu 5052	8,0	4,7	15,6 to 15,9	14,1 to 14,4
	SS 304Cu	15,5	4,0	14,8 to 15,0	13,6 to 14,0
M10 SPO 35	Steel C8C	15,5	4,5	16,1 to 16,3	15,5 to 15,7
	Alu 5052	-	-	-	-
	SS 304Cu	23,5	4,6	15,9 to 16,1	16,6 to 16,9

product	material	setting force	stroke	size bulb forming	length under plate
		kN	mm	mm	mm
M12 UPO 40	Steel C8C	20,5	6,5	20,8 to 21,0	17,5 to 18,0
	Alu 5052	-	-	-	-
	SS 304Cu	30,0	7,0	20,5 to 21,5	17,0 to 17,5
Hexagonal shank					
M4 HUPO 20	Steel C8C	5,5	2,8	7,6 to 8,3	6,1 to 6,4
	SS 304Cu	5,3	2,5	7,5 to 7,9	7,5 to 7,9
M5 HUPO 30	Steel C8C	6,1	4,0	9,8 to 10,4	7,8 to 8,2
	SS 304Cu	7,2	3,3	9,1 to 9,5	7,1 to 7,3
M6 HUPO 30	Steel C8C	11,5	3,6	11,4 to 12,5	9,7 to 10,1
	SS 304Cu	10,0	4,3	11,9 to 12,3	9,0 to 9,3
M8 HUPO 30	Steel C8C	14,0	4,6	14,3 to 15,4	10,7 to 11,1
	SS 304Cu	14,0	4,5	14,0 to 14,5	10,7 to 11,1
M10 HSPO 35	Steel C8C	13,0	5,5	17,5 to 18,6	14,4 to 14,7
	SS 304Cu	19,0	6,0	17,0 to 17,6	16,0 to 16,7
M12 HUPO 40	Steel C8C	21,0	6,6	20,7 to 21,6	15,0 to 16,1
	SS 304Cu	25,0	7,0	21,0 to 22,0	17,0 to 17,5

Length under plate of open end parts: values obtained after setting.

To obtain the length under the plate after setting of **closed end parts**, you can add the following sizes to the above-mentioned:

Steel and aluminium (mm)	
M3	3,5
M4	4,5
M5	6,0
M6	7,0
M8	8,0
M10	10,0
M12	10,0

Stainless steel (mm)	
M4	4,5
M5	6,0
M6	7,0
M8	8,0
M10	7,0
M12	10,0

In some cases the real length will be shorter. All dimensions can be checked on the technical data sheets in our catalogue.

In practice, variations may result from differing setting and environmental conditions. The values mentioned can be used as a reference and optimised by using additional features. We strongly advise customers to perform their own tests in the correct material thickness and specific application.

Grip range influences

The following values can be used as a guidance for other versions :

TYPE	Grip	ALUMINIUM			STEEL			STAINLESS STEEL 304 + 316		
		SETTING FORCE	STROKE	PULL-OUT	SETTING FORCE	STROKE	PULL-OUT	SETTING FORCE	STROKE	PULL-OUT
		N	mm	N	N	mm	N	N	mm	N
M3 UPO 20	1,0	2000	2,0	3750	4000	2,5	> 5000			
	2,0	2600	1,5	3280	4750	2,0	> 5000			
M3 UPO 30	2,0	1850	1,5	3900	3700	2,5	> 5000			
	3,0	2050	1,0	3968	4750	2,0	> 5000			
M4 UPO 20	1,0							4900	2,0	> 9000
	2,0							5500	1,5	> 9000
M4 UPO 30	1,0	2100	3,0	5170	4300	2,5	> 8000			
	3,0	2430	1,0	4330	5650	1,5	> 8000			
M4 UPO 35	2,0							5500	2,6	> 9000
	3,5							6000	1,7	> 9000
M4 UPO 45	3,0	2050	2,8	4838	4200	2,5	> 8000			
	4,5	2875	1,5	4421	5000	1,5	> 8000			
M5 UPO 30	1,0	3050	3,5	5500	6150	3,5	12240	7500	3,0	> 15000
	3,0	3650	2,0	5000	7200	2,5	9600	8500	1,7	> 15000
M5 UPO 50	3,0							7500	4,0	> 15000
	5,0							8500	2,0	> 15000
M5 UPO 55	3,0	3000	3,5	6450	5750	4,0	11800			
	5,5	4300	1,5	5525	9650	2,0	10300			
M6 UPO 30	1,0	4500	3,0	11000	9400	4,0	21200	11850	4,0	> 24000
	3,0	5750	2,0	10000	12000	3,0	18500	14460	3,0	> 24000
M6 UPO 50	3,0							13500	4,5	> 24000
	5,0							15000	2,8	> 24000
M6 UPO 55	3,0	4500	3,5	11000	9000	3,5	22700			
	5,5	6100	1,8	10000	11000	2,0	19700			
M6 UPO 80	5,5	4950	4,7	9160	8700	4,0	19900			
	8,0	5400	2,0	8200	11750	2,5	17200			
M8 UPO 30	1,0	5000	3,0	14900	11500	4,0	30400	14500	4,2	> 41000
	3,0	6600	2,0	14000	13750	2,5	26100	18000	2,8	> 41000
M8 UPO 55	3,0	5400	4,0	15500	11500	4,0	32500	14500	5,5	> 41000
	5,5	7400	2,0	11200	15500	2,5	31900	18500	3,0	> 41000

TYPE	Grip	ALUMINIUM			STEEL			STAINLESS STEEL 304 + 316		
		SETTING FORCE	STROKE	PULL-OUT	SETTING FORCE	STROKE	PULL-OUT	SETTING FORCE	STROKE	PULL-OUT
	mm	N	mm	N	N	mm	N	N	mm	N
M8 UPO 80	5,5	5900	4,0	16100	10700	4,0	32400			
	8,0	7850	2,0	13600	14700	2,5	26500			
M10 UPO 30	1,0							14500	3,5	> 45000
	3,0							18500	2,5	> 45000
M10 UPO 35	1,0	6750	4,0	22100	13600	4,5	39600			
	3,5	9000	2,5	17700	17000	2,5	32400			
M10 UPO 50	3,0							14500	3,5	> 39500
	5,0							18500	2,5	> 37000
M10 UPO 60	3,5	9000	5,0	25250	14900	4,0	42300			
	6,0	13000	3,0	23000	17900	2,5	31700			
M10 SPO 35	1,0				13500	4,5	40500	19500	4,5	> 45000
	3,5				16100	2,5	36100	26500	3,5	> 45000
M10 SPO 60	3,5				15900	5,5	48000	21000	5,5	> 45000
	6,0				20400	3,0	37500	25000	3,5	> 45000
M12 UPO 40	1,0				19500	5,5	> 50000	26000	8,0	> 75000
	4,0				25000	4,0	> 50000	34000	5,0	> 70000
M12 UPO 70	4,0				19500	5,5	> 50000	28000	8,0	> 75000
	7,0				25000	4,0	> 50000	37000	5,0	> 70000

Setting Force or Upset Load: Force (in Newton) necessary to deform the **Tubtara®** referred to in an adequate way.

Upset Stroke: Stroke (in mm) that should be set on the setting tool to give the **Tubtara®** referred to, the adequate deformation.

Pull-out or Ultimate Thread Strength: Surpassing this ultimate force (in Newton), the thread of the set **Tubtara®** will be pulled out.

The mentioned values are average reference values only.

We strongly advise the customer to do his own tests in the proper material thickness and specific application.

Semi-hex parts have a setting force which is 10 to 15% lower than full hex or round parts but have the same fixation strength.

● Testing methods

In addition to the standard inspections during the production process the following tests can be done on customer's request :

- Pull-out test
- Maximum torque
- Push-out test
- Shear test
- Torque-to-turn
- Length under plate
- Size bulb forming

● HX Tubtara® with seal under the head

Information about NBR O-Ring & compatibility with other products					
Shore Hardness	70 - 95	Aromatic Hydrocarbons	x	lye	x
Hydraulic fluids	xxxx	Aliphatic Hydrocarbons	xxx	Chlorinated Hydrocarbons	x
Fuel Oils	xx	Water under 80°C	xxx	Ozone & Sunlight	x
Organic Oils	xxxx	Water over 80°C	x	Temperature range °C	-35 +120
Brake Fluid	-	Alcohols	xx	Electr. properties	-
Silicone & Grease	xx	Ketone	-	Compression sets	xxx
Gasoline	xxx	Acid (concentrated)	-	Flame resistance	No
Aromatic fluids up to 50 %	xx	Acid (diluted)	x		
Kerosene	xxx				

Key: xxxx very good --> x satisfactory - not suitable.

Storage: protect against UV-light; store in a dry and dark place (all boxes are marked)

Seals in other materials like Viton or EPDM on request.

● (H)DPX Tubtara® with seal under the head

Information about the non-reactive, peripheral seal, made of flexible organic based material:

Material	Polyurethane	Reusability	yes
Colour	blue	Bead form	concave
Sealing capacity	> 150 bar	Cure method	heat cure
Temperature range	-40 +100 °C**	Waterproof	IP67 *
Shore hardness	50 A range		

Compatibility with other products : resistant to many automotive oils, antifreeze and transmission fluids.

* The seal reassures an IP67 waterproof Tubtara®-sheet assembly if correctly installed (only guaranteed under Dejong test conditions, certificates available)

Storage : min. 4 years shelf-life if stored in dry conditions (room temperature)

** For continuous usage, 150°C possible for intermittent use subject testing.

● Conversion table

Multiply	by	To get
millimeter (mm)	.03937	inch (in)
inch (in)	25,4	millimeter (mm)
kilogram (kg)	2,2046	pound (lb)
pound (lb)	0,4536	kilogram (kg)
Newton (N)	0,2248	pound-force (lbf)
Newton metre (Nm)	8,8507	pound-inch (Lb-In)

3D drawings

See our website www.tubtara.com and click on '3D drawings'

3D and 2D drawings available for all **Tubtara**[®] stainless steel blind rivet nuts:

- downloadable in installed or uninstalled condition
- user input option for exact grip
- multiple formats supported (DWG, STP, SolidWorks, Autodesk, Spaceclaim, AutoCAD, etc.)
- ability to insert **Tubtara**[®] CAD drawings directly into the product design

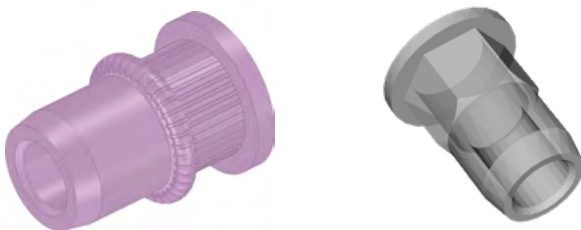

External website hosted by "Traceparts online":

www.tracepartsonline.net/ws/dejond

Quality

Statements on Reach / RoHS / Conflict Minerals:

- see our website www.tubtara.com or www.dejond.com
- contact our customer service for updated information.

EN 9100 - AS 9100 - JISQ 9100 certified



DEJOND IS NOT LIABLE FOR ANY PRINTING ERRORS AND RESERVES THE RIGHT TO CHANGE ALL DATA CONTAINED IN THIS CATALOGUE WITHOUT PRIOR NOTICE

Information cannot be copied or reproduced without permission of Dejond nv

General conditions available on our website www.dejond.com

Any dispute will fall within the exclusive jurisdiction of the courts of Antwerp